



Parts Manual

Mfg. No: 030238-0
3,750 Watt Briggs & Stratton

Model Components	Page
Alternator (191750).....	4
Control Panel (191751).....	6
Main Unit (197981).....	8
Wheel Kit (192621).....	12
Wiring Diagram (191562).....	14
Wiring Schematic (191562).....	16
Torque Specification Chart.....	18

Not For
Reproduction

Alternator (191750)

Note: Unless noted otherwise, use the standard torque specifications

Mfg. No: 030238-0

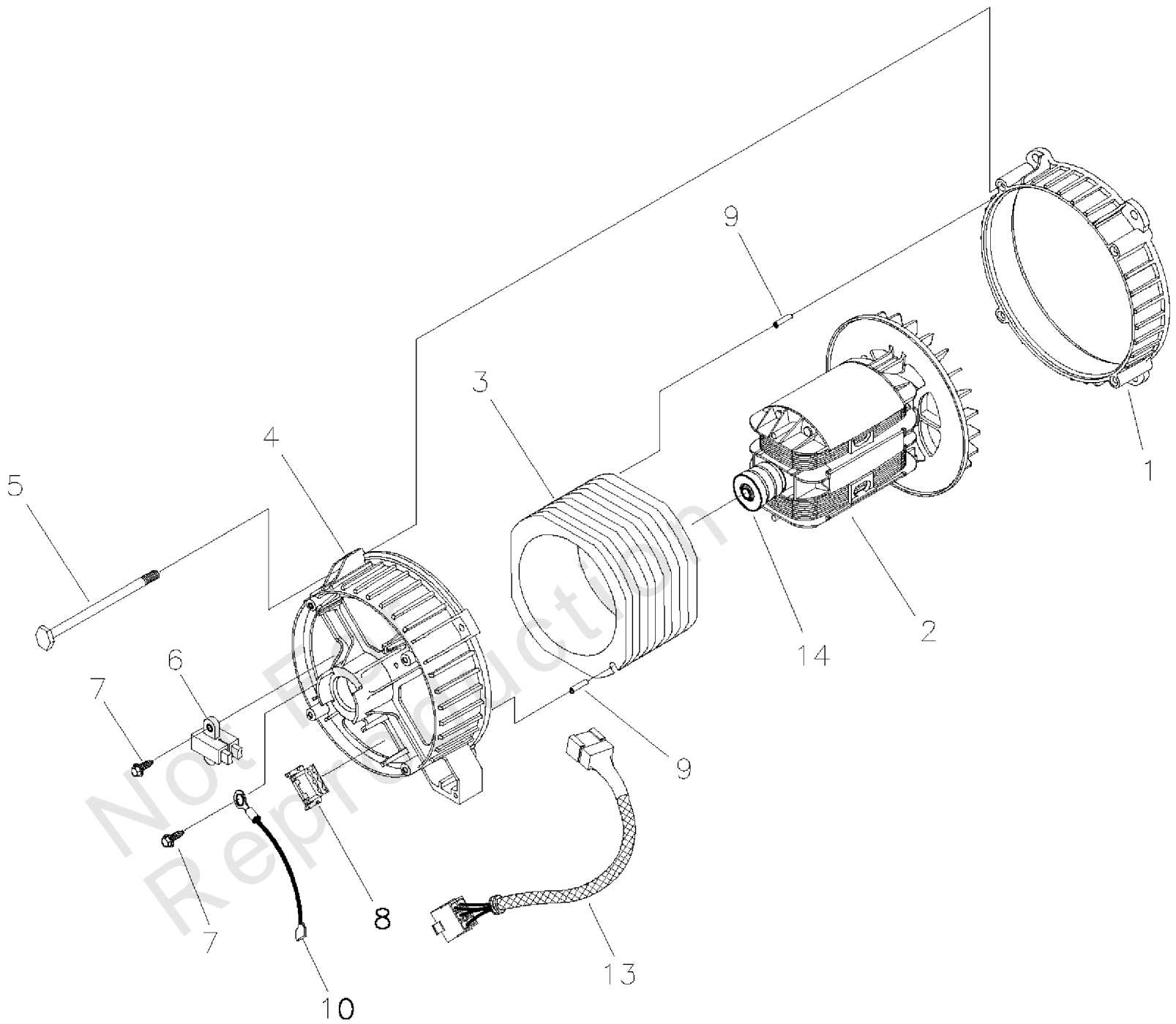

Alternator (191750)

REF NO	PART NO	QTY	DESCRIPTION
1	186059GS		ADAPTER, Mounting,Alternator
2	191685GS		ROTOR
3	191686AGS		STATOR
4	186060GS		RBC, with O-Ring (p/n 189197GS)
5	86308GS		HHCS, M6 - 1.0 x 115 SEMS
6	91825GS		ASSY, Holder, Rectifier/Brush
7	66849GS		TAPTITE, M5 - 0.8 x 16
8	22694GS		RECEPTACLE, 6 pin
9	81917GS		PIN, Roll, 4mm x 10
10	193428AGS		ASSY,Wire, Ground
13	194274GS		HARNESS,Wire, Power
14	65791GS		BEARING

Not For
Reproduction

Control Panel (191751)

Note: Unless noted otherwise, use the standard torque specifications

Mfg. No: 030238-0

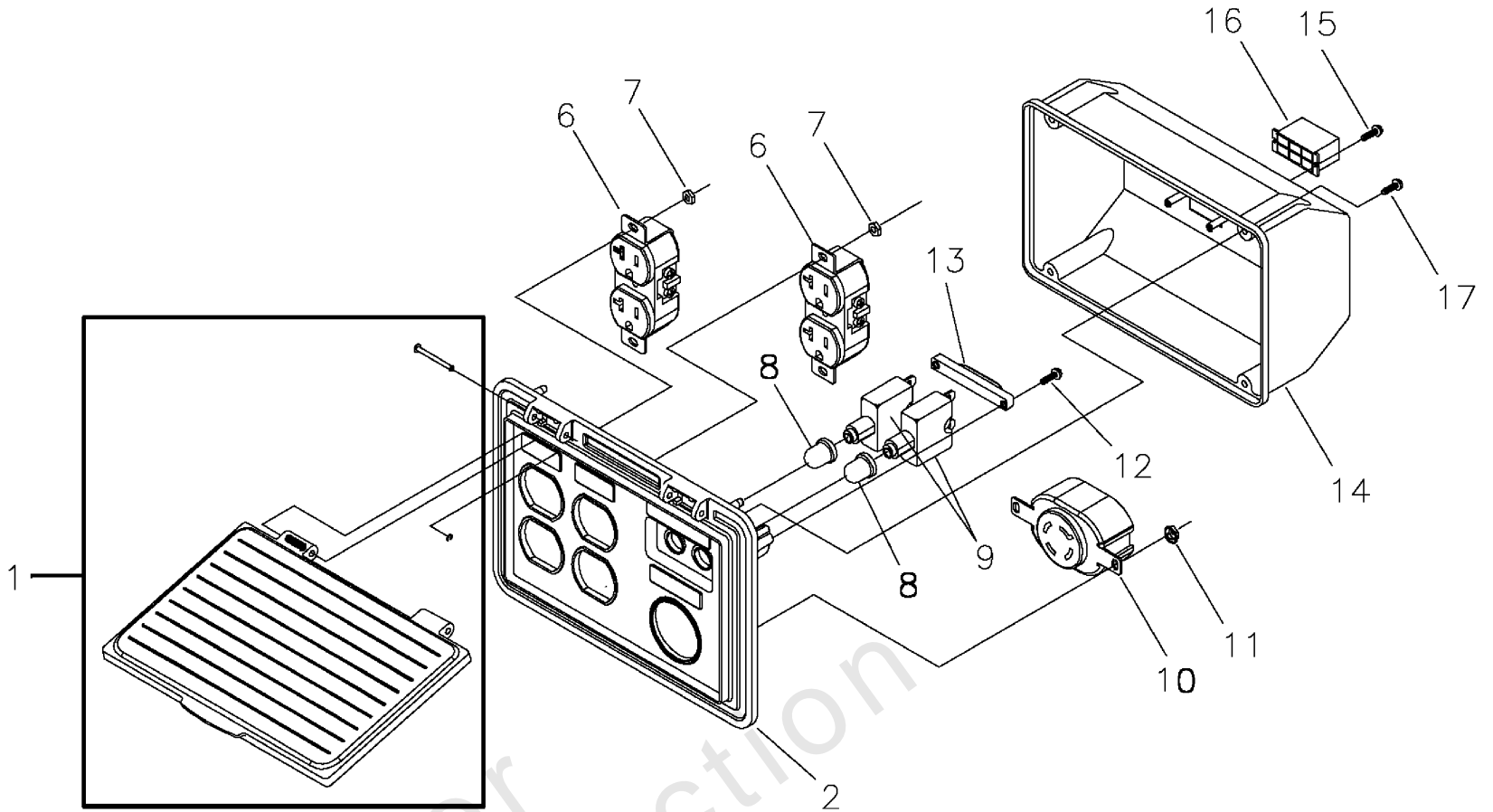

Control Panel (191751)

REF NO	PART NO	QTY	DESCRIPTION
1	195112GS		KIT, Cover Control Panel
2	188889AGS		CONTROL PANEL, Compact
6	68759GS		OUTLET, 120V, 20Amp, Duplex
7	-		NUT, Palnut, Pushnut, 5/32 -(Purchase locally)
8	84198GS		CAP, Breaker, Circuit
9	75207DGS		BREAKER, Circuit
10	68867GS		OUTLET, 120/240V Locking, 20A
11	-		NUT, Palnut, Pushnut, 3/16 -(Purchase locally)
12	-		PPPHS, M3 - 0.5 x 18 -(Purchase locally)
13	93857GS		BAR, Retaining
14	188890GS		COVER, Back, Control Panel
15	-		SCREW, 3 x 18, Tapping -(Purchase locally)
16	22694GS		HOUSING, Receptacle
17	-		SCREW, 3.5 x 14, Tapping -(Purchase locally)

Not For
Reproduction

Main Unit (197981)

Note: Unless noted otherwise, use the standard torque specifications

Mfg. No: 030238-0

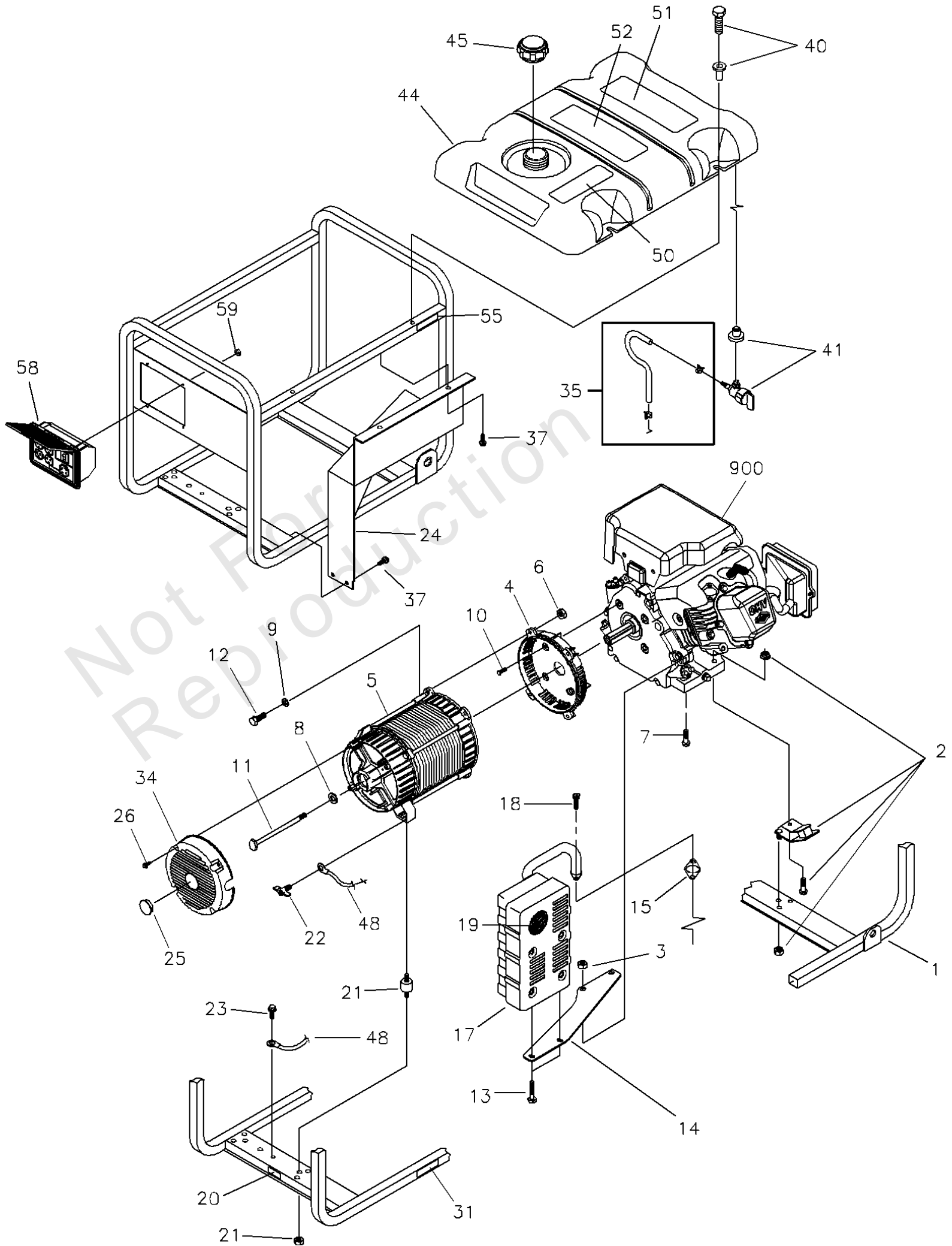

Main Unit (197981)

REF NO	PART NO	QTY	DESCRIPTION
1	R194779GS		KIT, Cradle -(Includes Items 20, 31 & 55)
2	194150GS		KIT,Vibration Mount
3	67989GS		NUT,M8 Flange Serrated
4	186058AGS		HOUSING,Engine Adapter
5	-		NSP ASSY,Alternator -(see "Alternator")
6	-		NUT, Hex, M8 - 1.25 -(Purchase Locally)
7	-		TPHMS,M8 1.25 x 35 -(Purchase Locally)
8	96796GS		WASHER
9	-		WASHER, 5/16 - M8, Lock -(Purchase Locally)
10	-		HHCS, 5/16-24 x 3/4,SEMS -(Purchase Locally)
11	24823GS		HHCS,5/16-24 x 7-7/8" Lg
12	-		HHCS,M8 - 1.25 x 25 -(Purchase Locally)
13	-		HHCS, M6 1.0 x 12 -(Purchase Locally)
14	191785GS		BRACKET, Muffler
15	697815		GASKET, Exhaust
17	188301GS		MUFFLER
18	-		SHCS, M6 - 1.0 x 20 -(Purchase Locally)
19	83083GS		SCREEN,Spark Arrest
20	B4986GS		DECAL, Ground
21	194153GS		KIT,Vibration Mount
22	86494GS		SCREW,Wing M6 - 1.0 x 16
23	86292GS		SCREW, 10-16 x 3/4, Self Drill
24	191790GS		SHIELD, Heat
25	191190GS		CAP
26	74908GS		TAPTITE,M5-0.8 x 10 Lg.
31	196830GS		DECAL, Caution Hot Muffler
34	195422GS		COVER,RBC with Cap
35	195207GS		KIT, Fuel Hose w/ Clips
37	B2153GS		HHCS, 12 - 14 x 7/8" Self Driller
40	194398GS		KIT, Fuel Tank Hardware -(Includes Qty of 4)
41	192980GS		KIT,Valve,Tank Fuel Service
44	193645GS		ASSY,Tank, Fuel -(Includes Items 41,50, 51 & 52)
45	200095GS		CAP
48	195373GS		WIRE,Ground
50	188333GS		DECAL, Fuel Level
51	194799GS		DECAL, Danger
52	189235GS		DECAL, Operating Instructions
55	197798GS		DECAL, Fuel Shut Off
58	191743AGS		ASSY, Control Panel -(see "Control Panel")
59	-		NUT, Palnut -(Purchase Locally)
900	-		ENGINE -Contact Engine Manufacturer

Main Unit (197981)

Note: Unless noted otherwise, use the standard torque specifications

Mfg. No: 030238-0

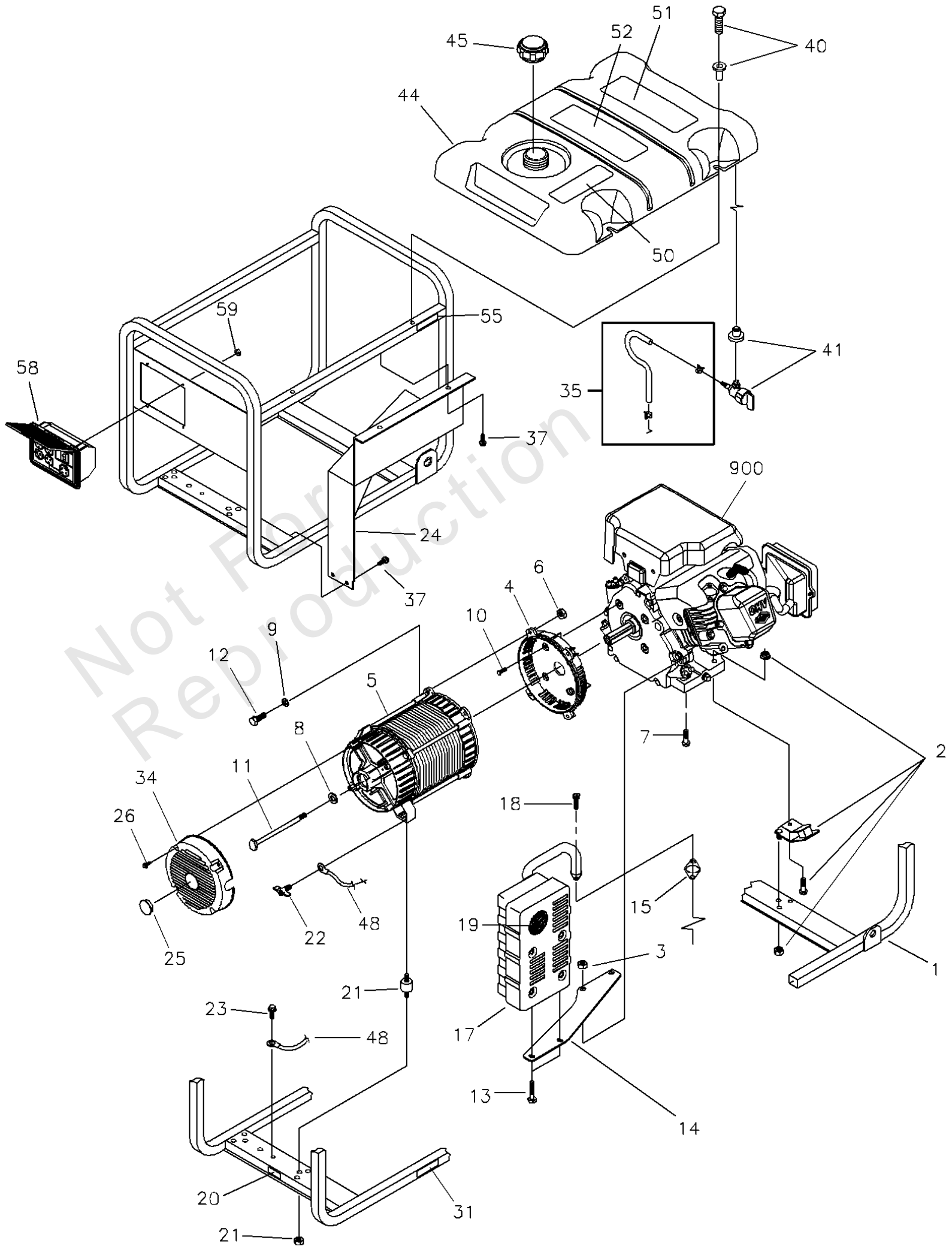

Main Unit (197981)

REF NO	PART NO	QTY	DESCRIPTION
	197980GS		MANUAL, Operator's -Parts Not Illustrated
	43483GS		PLUG, 250V, 20A -Parts Not Illustrated
	MS3430		MANUAL, Engine -Parts Not Illustrated
	BB3061BGS		BOTTLE OIL -Parts Not Illustrated
	199384GS		DECAL, Family, CA, EVP -Parts Not Illustrated
	198088GS		KIT, Decals Service -Parts Not Illustrated
	100031		STABILIZER, Fuel -Optional Accessories

Not For
Reproduction

Wheel Kit (192621)

Note: Unless noted otherwise, use the standard torque specifications

Mfg. No: 030238-0

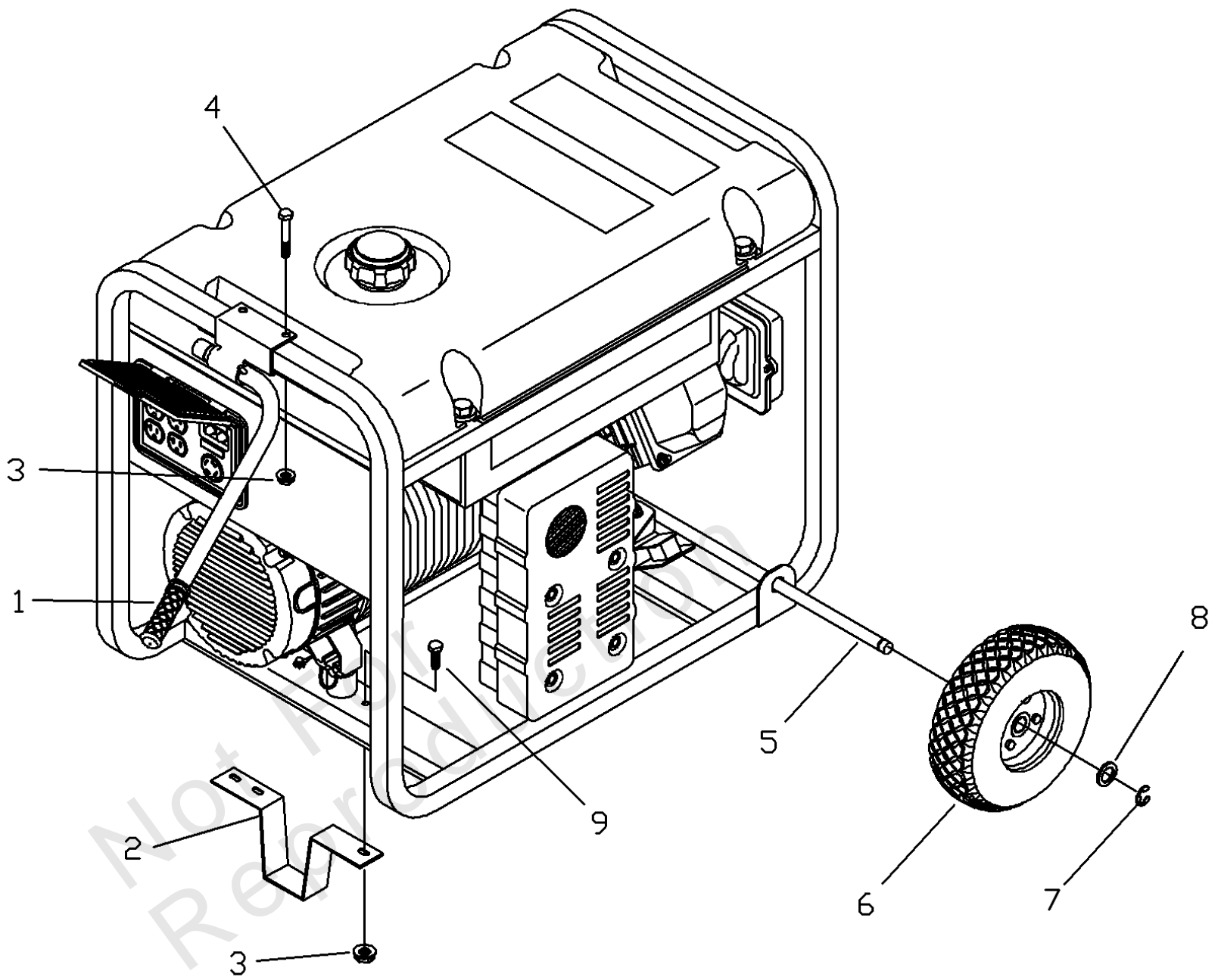

Wheel Kit (192621)

REF NO	PART NO	QTY	DESCRIPTION
1	189715GS		ASSY, Handle
2	B1764GS		LEG, Mounting
3	52858GS		NUT, Locking Hex M8 - 1.25
4	-		HHCS, M8 - 1.25 x 45 -(Purchase Locally)
5	191267NGS		AXLE
6	B4966GS		WHEEL, 10" Diameter
7	191265GS		E-RING
8	-		WASHER, Flat -(Purchase Locally)
9	-		HHCS, M8 - 1.25 x 16 -(Purchase Locally)
--	189718GS		GRIP, Handle -Not Illustrated

Not For
Reproduction

Wiring Diagram (191562)

REF NO	PART NO	QTY	DESCRIPTION
--	-		Wiring Diagram only
--	WARNING		Warning Generator Voltage Could Cause Electrical Shock or Burn Resulting in Death Or Serious Injury. To Avoid Electrical Shock Or Burn Hazard, Please Refer Service To Qualified Personnel.

Not For
Reproduction

Wiring Schematic (191562)

Note: Unless noted otherwise, use the standard torque specifications

Mfg. No: 030238-0

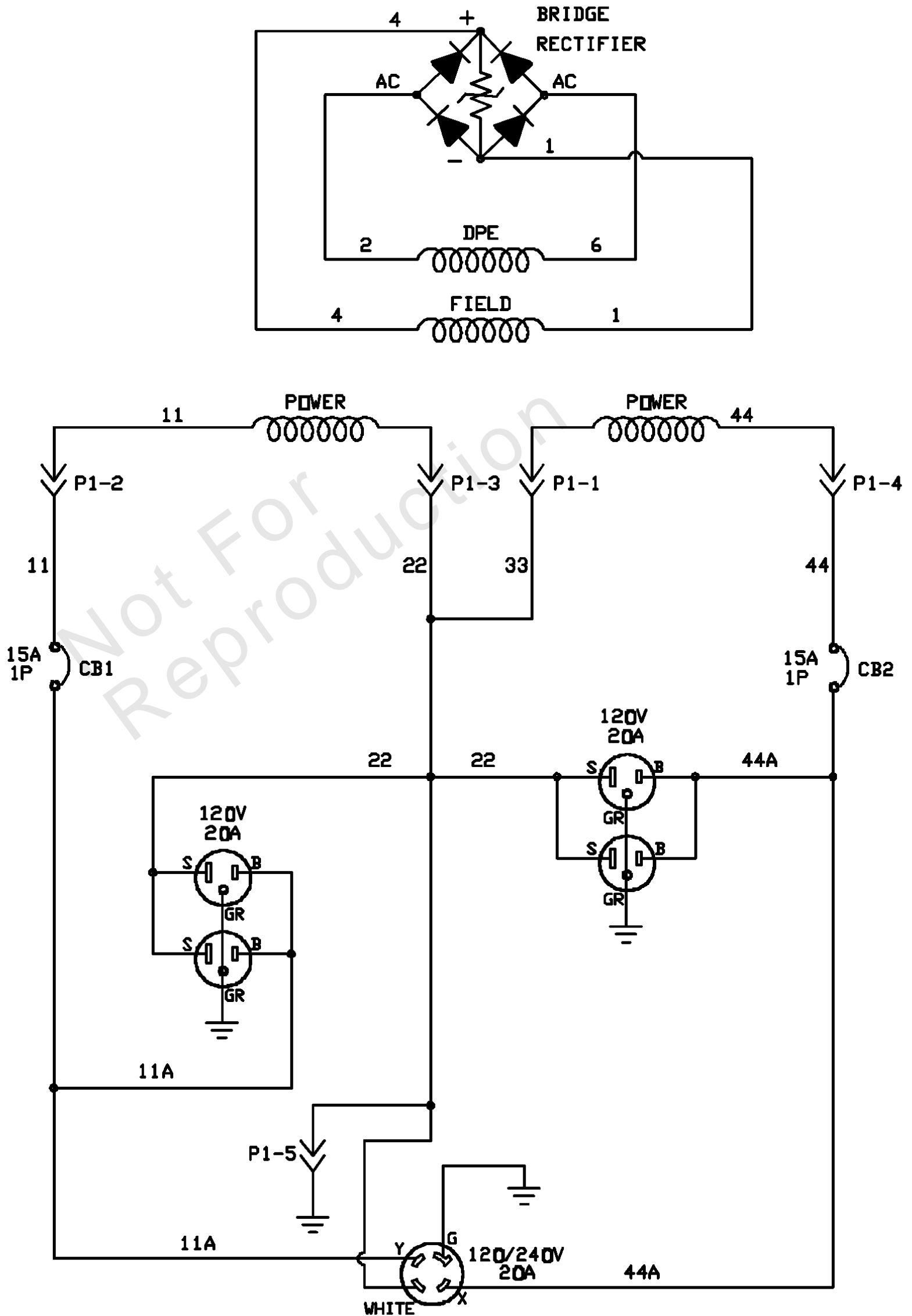

Wiring Schematic (191562)

REF NO	PART NO	QTY	DESCRIPTION
--	-		Wiring Schematic Only
--	WARNING		Warning Generator Voltage Could Cause Electrical Shock or Burn Resulting in Death Or Serious Injury. To Avoid Electrical Shock Or Burn Hazard, Please Refer Service To Qualified Personnel.

Not For
Reproduction

Hardware Identification & Torque Specifications

Torque Specification Chart								
FOR STANDARD METRIC MACHINE HARDWARE (Tolerance ± 20%)								
Property Class	5.6		8.8		10.9		12.9	
	Class 5.6		Class 8.8		Class 10.9		Class 12.9	
Size Of Hardware	in/lbs	Nm.	in/lbs	Nm.	in/lbs	Nm.	in/lbs	Nm.
	ft/lbs		ft/lbs		ft/lbs		ft/lbs	
M3	5.88	.56	13.44	1.28	19.2	1.80	22.92	2.15
M4	13.44	1.28	30.72	2.90	43.44	4.10	52.56	4.95
M5	26.4	2.50	60.96	5.75	5.97	8.10	7.15	9.7
M6	44.64	4.3	7.3	9.9	10.3	14	12.1	16.5
M7	5.2	7.1	12.1	16.5	16.9	23	19.9	27
M8	7.7	10.5	17.7	24	25	34	29	40
M10	15	21	35	48	50	67	59	81
M12	26	36	61	83	86.2	117	103	140
M14	42	58	101	132	136	185	162	220
M16	64	88	147	200	210	285	250	340
M18	89	121	202	275	287	390	346	470
M20	126	171	290	390	405	550	486	660
M22	169	230	390	530	559	745	656	890
M24	217	295	497	375	708	960	840	1140
M27	320	435	733	995	1032	1400	1239	1680
M30	435	590	995	1350	1401	1900	1681	2280
M33	590	800	1349	1830	1902	2580	2278	3090
M36	759	1030	1740	2360	2441	3310	2935	3980
M39	988	1340	2249	3050	3163	4290	3798	5150

Torque Specification Chart						
FOR STANDARD MACHINE HARDWARE (Tolerance ± 20%)						
Hardware Grade	No Marks		SAE Grade 5		SAE Grade 8	
	SAE Grade 2		SAE Grade 5		SAE Grade 8	
Size Of Hardware	in/lbs	Nm.	in/lbs	Nm.	in/lbs	Nm.
	ft/lbs		ft/lbs		ft/lbs	
8-32	19	2.1	30	3.4	41	4.6
8-36	20	2.3	31	3.5	43	4.9
10-24	27	3.1	43	4.9	60	6.8
10-32	31	3.5	49	5.5	68	7.7
1/4-20	66	7.6	8	10.9	12	16.3
1/4-28	76	8.6	10	13.6	14	19.0
5/16-18	11	15.0	17	23.1	25	34.0
5/16-24	12	16.3	19	25.8	29	34.0
3/8-16	20	27.2	30	40.8	45	61.2
3/8-24	23	31.3	35	47.6	50	68.0
7/16-14	30	40.8	50	68.0	70	95.2
7/16-20	35	47.6	55	74.8	80	108.8
1/2-13	50	68.0	75	102.0	110	149.6
1/2-20	55	74.8	90	122.4	120	163.2
9/16-12	65	88.4	110	149.6	150	204.0
9/16-18	75	102.0	120	163.2	170	231.2
5/8-11	90	122.4	150	204.0	220	299.2
5/8-18	100	136	180	244.8	240	326.4
3/4-10	160	217.6	260	353.6	386	525.0
3/4-16	180	244.8	300	408.0	420	571.2
7/8-9	140	190.4	400	544.0	600	816.0
7/8-14	155	210.8	440	598.4	660	897.6
1-8	220	299.2	580	788.8	900	1,244.0
1-12	240	326.4	640	870.4	1,000	1,360.0

The guides and ruler furnished below are designed to help you select the appropriate hardware.



Nut, M8

Thread Diameter (mm)

Inside Diameter (in) Threads per inch

Nut, 1/2-16

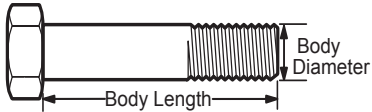

Screw, M8- 1.25 x 25

Thread Diameter (mm) Distance between threads (mm) Body Length (mm)

Body Diameter Threads per inch Body Length (in)

Screw, 1/2- 16 x 2



Standard Hardware Sizing

When a washer or nut is identified as 1/2" (M8), this is the *Nominal size*, meaning the *inside diameter* is 1/2 inch (8mm metric thread diameter); if a second number is present it represents the *threads per inch* (distance between threads).

When bolt or capscrew is identified as 1/2 - 16 x 2" (M8 - 1.25 x 50), this means the *Nominal size*, or body diameter is 1/2 inch (8mm metric thread diameter), the second number, 16, represents the *threads per inch*, (*distance between threads*). The final number is the body length of the bolt or screw, 2 inches (50mm).

NOTES

- These torque values are to be used for all hardware excluding: locknuts, self-tapping screws, thread forming screws, sheet metal screws and socket head setscrews.
- Recommended seating torque values for locknuts:
 - for prevailing torque locknuts - use 65% of grade 5 torques.
 - for flange whizlock nuts and screws - use 135% of grade 5 torques.
- Unless otherwise noted on assembly drawings, all torque values must meet this specification.

Common Hardware Types

Hex Head Capscrew



Washer



Carriage Bolt



Hex Nut

Wrench & Fastener Size Guide

1/4" Bolt or Nut Wrench—7/16"	5/16" Bolt or Nut Wrench—1/2"	3/8" Bolt or Nut Wrench—9/16"	7/16" Bolt or Nut Wrench (Bolt)—5/8" Wrench (Nut)—11/16"	1/2" Bolt or Nut Wrench—3/4"
M6 Bolt or Nut Wrench—10mm	M8 Bolt or Nut Wrench—13mm	M10 Bolt or Nut Wrench—17mm	M12 Bolt or Nut Wrench—19mm	M14 Bolt or Nut Wrench—22mm

